



# BUILT-IN SERIES

## Owner's Manual

BIR32RB

Appliance illustrated in this manual  
may differ from model purchased.



We Want Your Feedback!  
Visit [Napoleon.com](http://Napoleon.com) to write a review



Apply Serial Number

# CONGRATULATIONS ON YOUR NAPOLEON® GRILL!

You've Just Upgraded Your Cooking Game.



**OUR GOAL IS TO MAKE YOUR COOKING EXPERIENCE  
BOTH MEMORABLE AND SAFE.**

 Please read this Owner's Manual before using the appliance to avoid property damage, personal injury, or death.

 Remove all packaging material, promotional labels and cards from the grill before use.

**DO NOT OPERATE IN A BUILDING, GARAGE, OR ANY OTHER ENCLOSED AREA.**

## **DANGER!**

### IF YOU SMELL GAS:

- Shut off gas to the appliance.
- Extinguish any open flame.
- Open lid.
- If odor continues, keep away from the appliance and immediately call your gas supplier, or fire department.

## **WARNING!**

Do not try to light this appliance without reading the "LIGHTING" instructions section of this manual.

Do not store or use gasoline, or other flammable liquids or vapors in the vicinity of this or any other appliance.

A gas cylinder not connected for use must not be stored in the vicinity of this or any other appliance.

If the information in these instructions is not followed exactly, a fire or explosion may result and cause property damage, personal injury, or death.



Alert adults and children about the hazard of hot surface temperatures.



Supervise young children near the grill.

**NOTICE TO INSTALLER:** Leave these instructions with the grill owner for future reference.

**NOTICE TO CONSUMER:** Keep these instructions for future reference.

# Welcome to Napoleon!

## Safety First

### **WARNING!**

#### General Information

This grill should be installed in conformity with local codes. If an external electrical source is utilized, the appliance must also be grounded in accordance with local codes.

### **WARNING!**

#### Installation & Assembly

Assemble the grill exactly as shown in the Assembly Guide. If your grill was assembled in-store, review the instructions to confirm it was assembled correctly. Perform the required leak test before using the grill.

Never modify the grill. Use only the pressure regulator and hose assembly provided with the grill, or replacement parts approved by Napoleon.

### **WARNING!**

#### Operation

Read the entire Owner's Manual before operating the grill. This is an outdoor gas barbecue and must be used outdoors only in a well-ventilated area.

Do not operate in a building, garage, or any other enclosed space.

Perform a leak test before each use, annually, and whenever any gas components are replaced. Follow the lighting instructions carefully.

### **WARNING!**

#### Electrical Precautions

Keep all electrical cords and fuel supply hoses away from heated surfaces. Connect all electrical components to the appliance before plugging it into an outlet.

Use only a Ground Fault Interrupter (GFI) protected circuit with this outdoor cooking appliance. Never remove the grounding plug. Use only extension cords rated for the appliance's power and approved for outdoor use with a W-A marking.

### **WARNING!**

#### Storage & Disuse

Turn off the gas at the supply valve. Disconnect the hose between the gas cylinder and the grill.

Remove the gas cylinder and store it outdoors in a well-ventilated area, away from children. DO NOT store gas cylinders in a building, garage, shed, or any other enclosed space.

### **WARNING!**

#### Correct Product Disposal



This marking indicates that this product should not be disposed with other household wastes throughout the EU. To prevent possible harm to the environment or human health from uncontrolled waste disposal, recycle it responsibly to promote the sustainable reuse of material resources. To return your used device, please use the return and collection systems or contact the retailer where the product was purchased. They can take this product for environmental safe recycling.

## CONTENTS

---

|   |           |
|---|-----------|
| <b>Welcome to Napoleon!</b>             | <b>3</b>  |
| Safety First                            | 3         |
| <b>Full System Features</b>             | <b>5</b>  |
| <b>Getting Started</b>                  | <b>6</b>  |
| Additional Safe Operating Practices     | 6         |
| Cut-Out Dimensions                      | 8         |
| Gas Connections                         | 9         |
| Built-in Enclosure                      | 11        |
| Leak Test                               | 12        |
| <b>Operation</b>                        | <b>13</b> |
| Lighting your grill                     | 13        |
| Grilling Instructions                   | 15        |
| How to use the Rear Burner & Rotisserie | 16        |
| The Cooking Experience Checklist        | 18        |
| Seasoning Cast Iron Cooking Grids       | 18        |
| <b>Cooking Guide</b>                    | <b>19</b> |
| <b>Cleaning Instructions</b>            | <b>20</b> |
| First Time Use                          | 20        |
| Cast Iron Grids                         | 20        |
| Stainless Steel Grids                   | 20        |
| Infrared Side Burner                    | 20        |
| Inside of the Grill                     | 21        |
| Drip Tray                               | 21        |
| Control Panel                           | 22        |
| Aluminum Castings                       | 22        |
| Outside Appliance Surface               | 22        |
| Insect Screen and Burner Ports          | 23        |
| <b>Maintenance Instructions</b>         | <b>24</b> |
| Recommendations                         | 24        |
| Flame Appearance                        | 24        |
| Technical Data                          | 25        |
| Stainless in Harsh Environments         | 26        |
| <b>Troubleshooting</b>                  | <b>27</b> |
| <b>Warranty</b>                         | <b>30</b> |

# Full System Features

**ACCU-PROBE™** Temperature Gauge to easily read the temperature for perfect results

Single Rear Infrared Rotisserie Burner. Perfect for high heat searing and slow spit roasting.

Rotisserie mount brackets for convenient assembly on both sides of grill.

Instant **JETFIRE™** Ignition for quick and ease start-up

Large Stainless Steel Warming Rack for increased cooking area.

Dual-level Stainless Steel Sear Plates for consistent even heating and vaporizing drippings for more flavourful food.

Large Cast iron Iconic **WAVE™** cooking grids with dual position for those distinctive sear marks.

Easy access to drip pan for efficient maintenance.

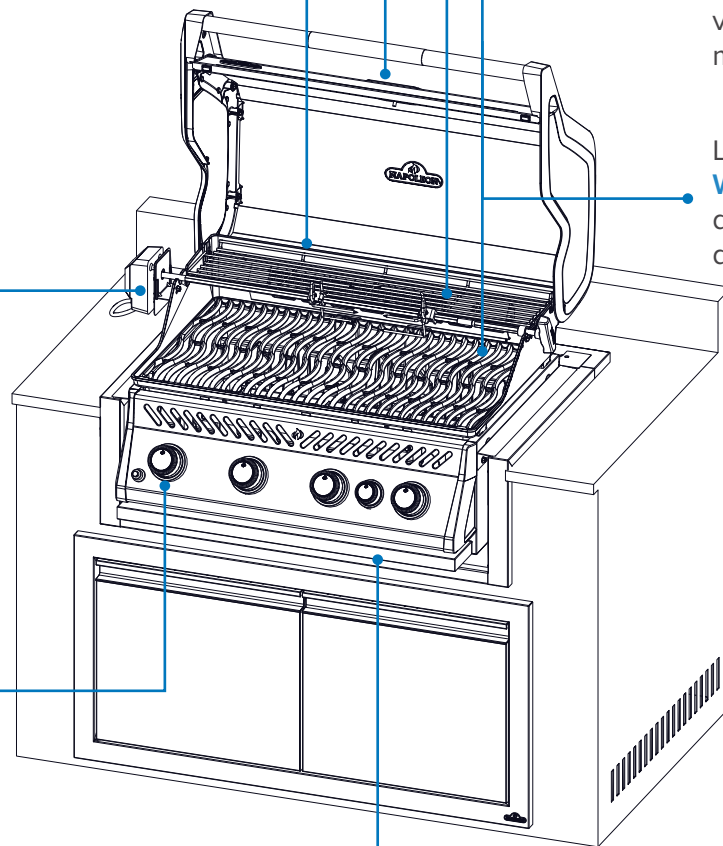

**!** The grill illustrated in this Owner's Manual may differ from the model you purchased.  
Featured model: BUILT-IN BIR32RB

## Getting Started



### DANGER!

Advises of a hazard that could result in a fire, explosion, death or serious physical injury.



### WARNING!

Advises of a hazard that could result in minor physical injury or property damage.



Do not smoke while performing a gas leak test. Sparks or flames will cause a fire, explosion, damage to property, serious physical injury, or death.



Never use an open flame to check for gas leaks. Sparks or flames will cause a fire, explosion, damage to property, serious physical injury, or death.



**CAUTION!** Hot surface.



Immediately shut off the gas supply and disconnect.



Wear safety glasses.



Wear protective gloves.



Important Information.

## Additional Safe Operating Practices

- DO NOT route the hose underneath the drip pan. Keep proper clearance between the hose and the bottom of the unit.
- Ensure sear plates are positioned correctly according to the installation instructions.
- Make sure burner controls are OFF before turning the gas cylinder valve ON.
- DO NOT light burners with the lid closed.
- DO NOT operate the rear burner(s) at the same time as the main burners.
- DO NOT close the side burner lid while operating or when hot.
- DO NOT deep fry food on the side burner.
- DO NOT adjust the cooking grids while operating or when hot.
- DO NOT move the appliance while in use.
- Turn off the gas supply at the source after each use.
- DO NOT modify the appliance.
- Perform maintenance only when the grill is cool.
- DO NOT store lighters, matches, or any other combustible materials inside the enclosure or condiment tray.
- Keep all electrical cords and fuel supply hoses away from heated surfaces.
- Clean the grease tray, drip pan, and sear plates regularly to prevent grease build-up and fires.
- Keep the infrared burner and main burner venturi tubes free from spider webs and other obstructions by inspecting and cleaning them regularly.

- DO NOT allow cold water (rain, sprinkler, or hose) to contact the heated grill. Sudden temperature changes can damage porcelain surfaces and crack ceramic burners.
- DO NOT use a pressure washer to clean any part of the grill.
- DO NOT locate this grill where it can be exposed to high winds, especially from directly behind.
- DO NOT operate this appliance under combustible construction.
- DO NOT cover more than 75% of the cooking surface with solid metal.
- Keep the appliance away from flammable materials while in use. Maintain at least 24" (610 mm) clearance at the rear and 7" (178 mm) at the sides.
- Allow at least 24" (610 mm) clearance near vinyl siding or glass panels.
- Always maintain a minimum clearance to combustibles of 17" (431 mm) at the rear and 9" (229 mm) at the sides.
- For BIB18PB models, maintain a minimum clearance of 17" (431 mm) at the rear and 20" (508 mm) at the sides.
- Maintain at least 17" (431 mm) clearance between this grill and any other appliance.



## WARNING!

- The hook-up and installation of the gas and hose connection must be performed by a licensed gas fitter, and leak tested before operating the grill.
- Ensure the hoses do not contact any high temperature surfaces of the grill.
- Accessible parts may be very hot. Keep young children away.

## Cut-Out Dimensions

| Model | Opening Dimensions<br>(in /cm) |                    |     |                     | Opening Dimensions (in /cm)<br>Installing Zero Clearance Liner |                  |                     |                     |                     |
|-------|--------------------------------|--------------------|-----|---------------------|--|------------------|---------------------|---------------------|---------------------|
|       | W                              | X                  | D   | H                   | W  | X                | D                   | H                   |                     |
| BIR32 | Min                            | 30.5 in<br>77.4 cm | N/A | 20.81 in<br>52.8 cm | 9.5 in<br>24 cm  | 34 in<br>86.4 cm | 35.38 in<br>89.9 cm | 21.38 in<br>54.3 cm | 10.38 in<br>26.4 cm |
|       | Max                            | 32 in<br>81 cm     | N/A | --                  | --   | --               | --                  | --                  | --                  |

**A** = 6.5" (16.5 cm)

**B** = 6.5" (16.5 cm)

**C** = 5.7" (14.5 cm) MIN.

**E\*** = 4.25" (10.8 cm) MAX.

**E\*** = For use with the installation of a Napoleon BI door.

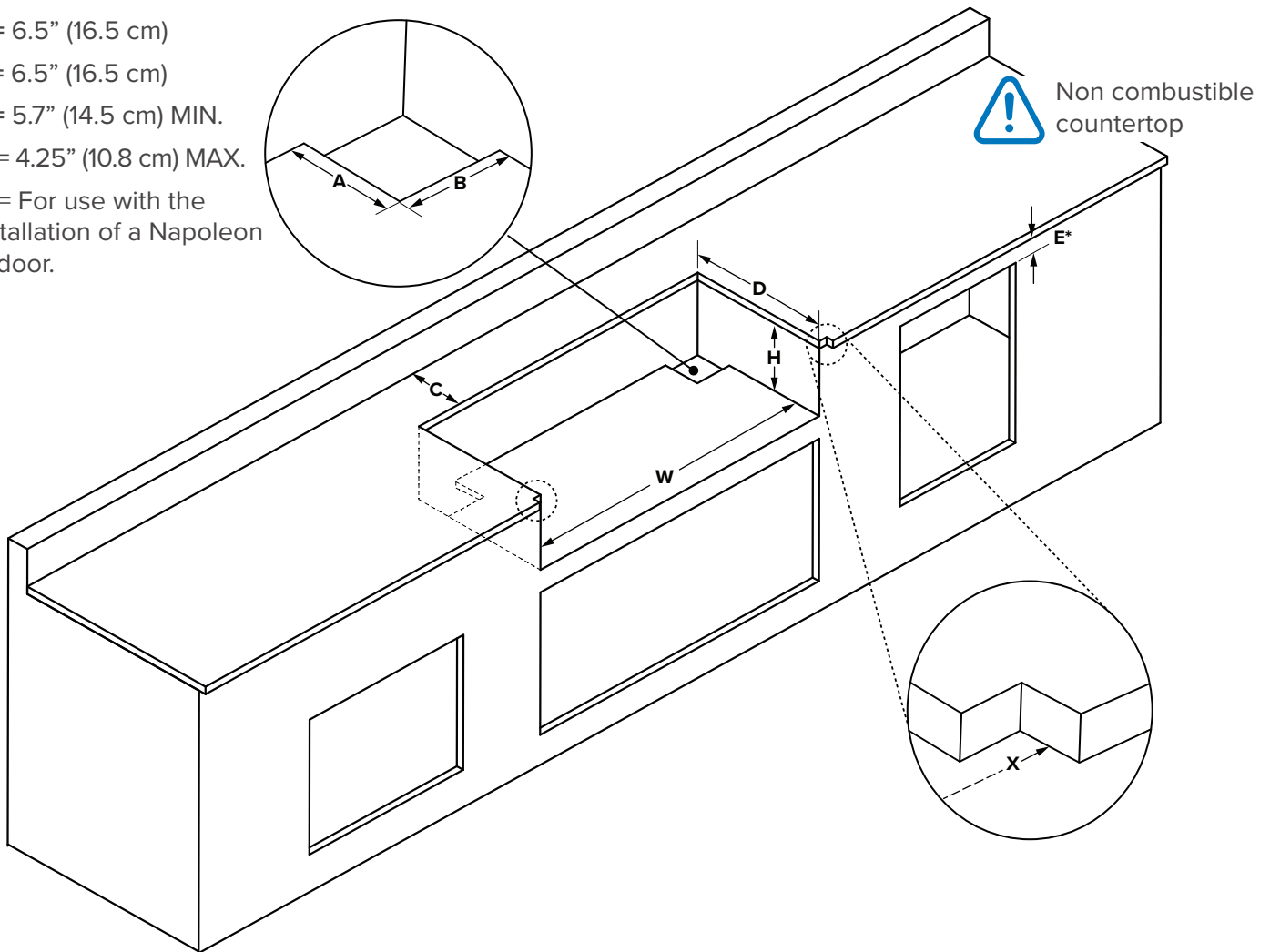

### ! WARNING!

- The cabinet frame and cabinet **MUST** be made of non-combustible material if the appliance is not installed with the Zero Clearance Liner

designed for your unit. Refer to the parts list in the Assembly Guide for details.

- If the enclosure contains an LPG cylinder, it must be built

according to the cylinder enclosure instructions. Refer to Gas Connections for more information.

## Gas Connections

### Gas Cylinder

Use a propane cylinder with a minimum capacity of 6 kg, or a butane cylinder with a capacity of 13 kg, constructed and marked in accordance with national and regional codes. Make sure the cylinder can supply enough fuel to operate the appliance. If in doubt, consult your local gas supplier.

 **NOTE:** For best performance, operate the grill on propane gas.

Only cylinders connected to the appliance may be stored in the enclosure. Cylinders must fit within the maximum width and height dimensions of the built-in enclosure. **DO NOT** store spare cylinders in the enclosure or near an operating unit.

### Connection to a Gas Supply Line

This grill must operate at the gas supply pressure shown on the rating plate. If the supply pressure is higher, a regulator must be installed upstream of the grill. If the supply pressure is lower, the unit will be under-fired and will not reach maximum temperatures.

Use the gas pressure regulator and hose supplied by Napoleon. If not included, use a regulator and hose that meet national and regional codes. The recommended hose length is 0.9 m (36"). The hose must never exceed 1.5 m (60"). Inspect the hose regularly for cuts, melting, or wear, and replace it if needed.

 **NOTE:** Replace the hose before the expiry date printed on it.

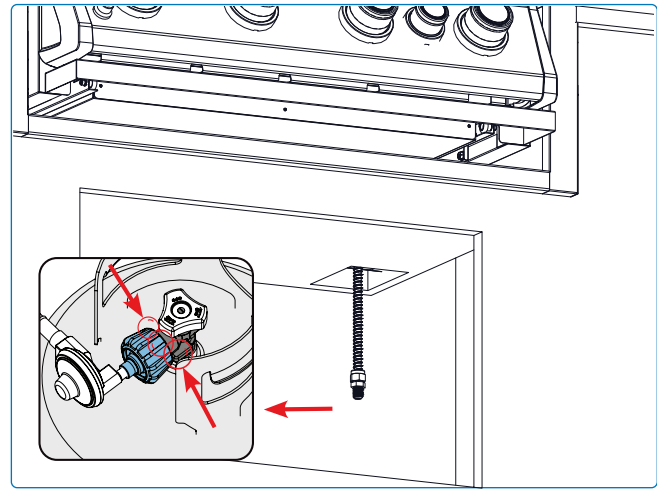

- The gas pipe must be sized to supply the kW listed on the rating plate, based on the length of the piping run.
  - If you are installing a side burner, run a separate gas line through the designated opening for that location.
1. Install a readily accessible manual shut-off valve upstream of the unit. A flexible metal connector is included to simplify installation. Connect the other end of the connector to the gas piping.
  2. Tighten all connections with two wrenches. **DO NOT** use thread sealer or pipe dope.
  3. Ensure the connector does not pass through a wall, floor, ceiling, or partition, and that it is protected from damage.
  4. Leak-test all joints before operating the grill. See **“Leak Test”**.



### WARNING!

- The connectors must be of rigid pipe, copper tube or approved flexible metal which must comply with national and regional codes.

## Hook-up and Installation

- Check the cylinder for dents or rust, and have it inspected by your propane supplier. **DO NOT** use a cylinder with a damaged valve.
- Place the cylinder in the designated area of the enclosure.
- Ensure the gas regulator hose is free of twists or kinks.
- Remove the cap or plug from the cylinder fuel valve.
- Tighten the regulator securely to the cylinder valve.
- Ensure the hose does not touch the drip pan or any hot surfaces of the grill. Contact with heat can cause the hose to melt and start a fire.
- **DO NOT** leave the cylinder exposed to extreme heat or direct sunlight.
- Leak-test all joints before operating the grill. See “**Leak Test**” section.



**NOTE:** Inspect the gas cylinder valve seal for cracks, wear, or deterioration each time the cylinder is replaced or refilled.

Any gas cylinder showing signs of damage or deterioration, including visible cracks and pitting, must be returned unused to the seller.

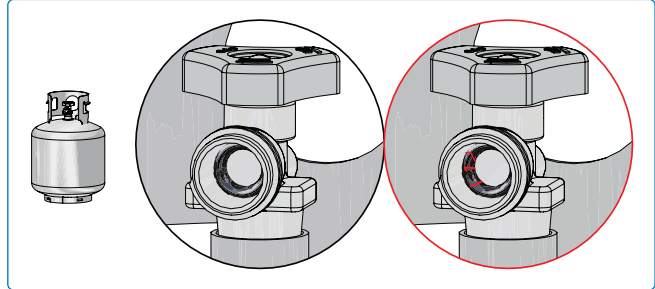

## WARNING!

- **DO NOT** store a spare gas cylinder beneath the grill head or side burners.
- Disconnect the grill and its shut-off valve from the gas supply piping system during any pressure testing.
- Check the hose for evidence of excessive abrasion, melting, cuts or cracks. If the hose is damaged, it must be replaced with an assembly specifically recommended by Napoleon.
- Follow all specifications and instructions exactly to prevent fire, explosion, property damage, personal injury, or death.

## Built-in Enclosure

- The enclosure must allow the gas cylinder to be connected, disconnected, and inspected or leak-tested outside of it. Connections that could be disturbed during installation may be leak-tested inside the enclosure.
- The cylinder must be isolated from the grill enclosure and protected from heat, flames, hot drippings, and other hazardous materials.
- A door on the enclosure is acceptable if it is non-locking and can be opened without tools.
- Maintain a minimum clearance of 2 in (5.08 cm) between the floor of the cylinder enclosure and the ground.
- Ensure at least two unobstructed ventilation openings on the exposed exterior side of the enclosure: one within 5 in (12.7 cm) of the top and another within 1 in (2.54 cm) of the cylinder opening's bottom surface.
- The top opening must provide a free area of more than 20 in<sup>2</sup> (130 cm<sup>2</sup>) for a 20 lb (9.1 kg) cylinder and more than 30 in<sup>2</sup> (195 cm<sup>2</sup>) for a 30 lb (13.6 kg) cylinder.
- The bottom opening must provide a free area of more than 10 in<sup>2</sup> (65 cm<sup>2</sup>) for a 20 lb (9.1 kg) cylinder and more than 15 in<sup>2</sup> (100 cm<sup>2</sup>) for a 30 lb (13.6 kg) cylinder.
- The upper edge of the bottom openings must be no more than 5 in (127 mm) above the floor (**Fig. 0**).
- Every opening must be large enough to allow the entrance of a 3/16 in (4.8 mm) rod.
- The size of the openings must correspond to the cylinder size.

### Maximum Cylinder Dimensions

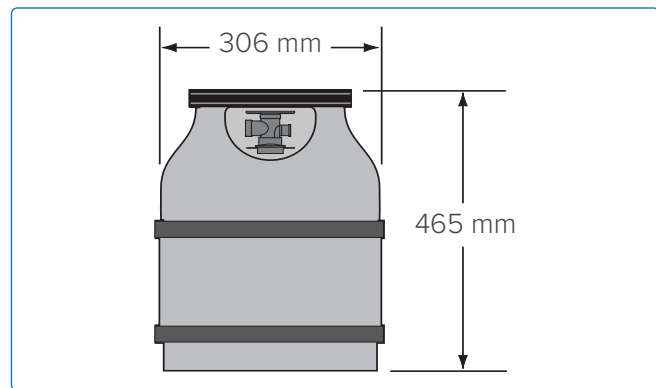

| Cylinder Size   | Opening A Area (Top)                      | Opening B Area (Bottom)                   |
|-----------------|---|---|
| 20 lb (9.1 kg)  | 20 in <sup>2</sup> (130 cm <sup>2</sup> ) | 10 in (65 cm <sup>2</sup> )               |
| 30 lb (13.6 kg) | 30 in <sup>2</sup> (195 cm <sup>2</sup> ) | 15 in <sup>2</sup> (100 cm <sup>2</sup> ) |

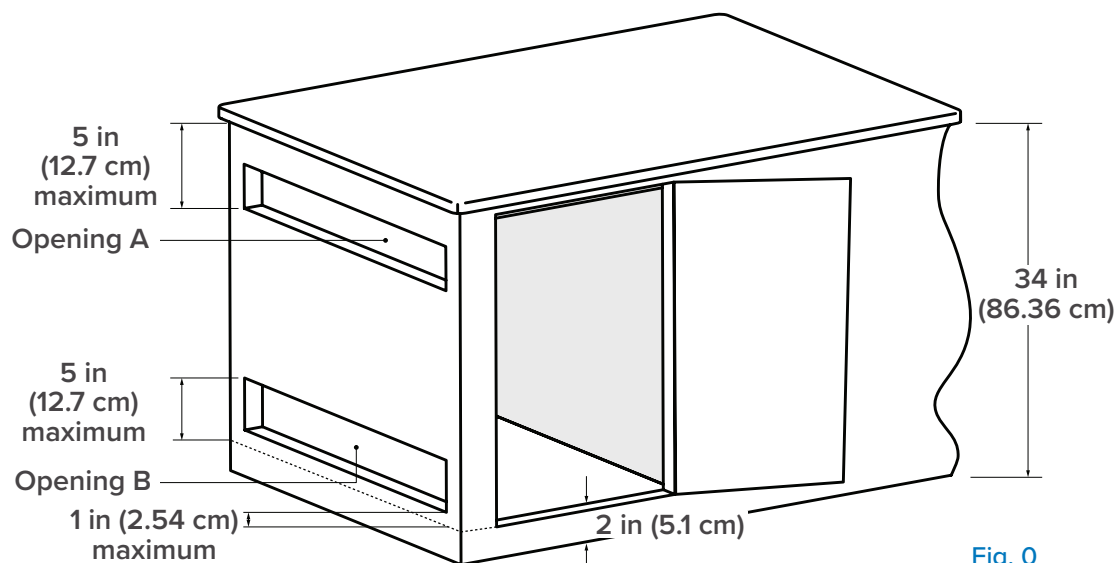

Fig. 0

## Leak Test

### Why and When to Leak Test?

A leak test confirms no gas is escaping after you connect the hose to the gas supply.

Each time the tank is refilled and reinstalled, ensure that there are no leaks in the fitting where the regulator connects to the tank.

Leak test this grill before use, annually, and when any gas components are replaced.

### Leak Test Steps

1. Do not smoke while performing the test.
2. Remove all sources of ignition.
3. Turn all burner controls to the off position.
4. Turn the gas supply valve on.
5. Brush a half-and-half solution liquid soap and water onto all joints and connections of the regulator, hose, manifolds, and valves.
6. Bubbles indicate a gas leak.

### If you Find a Leak

1. Tighten any loose joints.
2. If the leak cannot be stopped, immediately shut off the gas supply and disconnect the grill.
3. Have the grill inspected by a certified installer, or dealer.
4. Do not use the grill until the leak has been fixed.

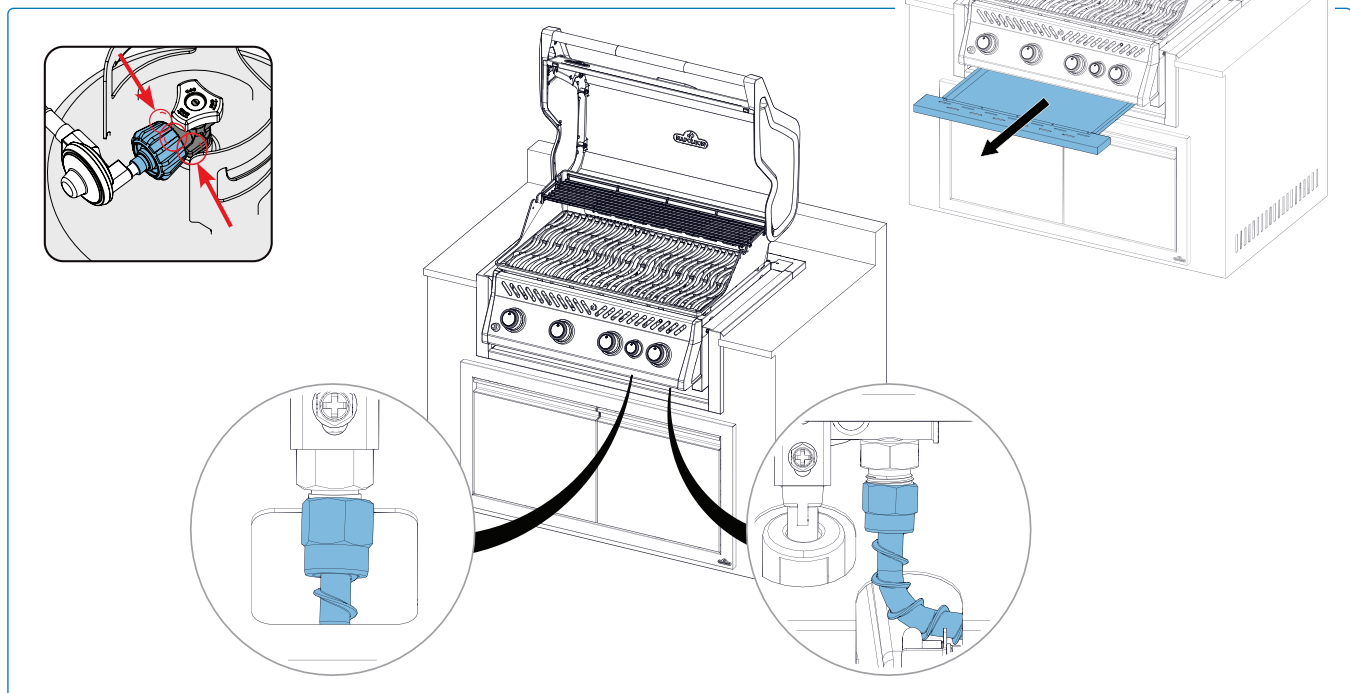
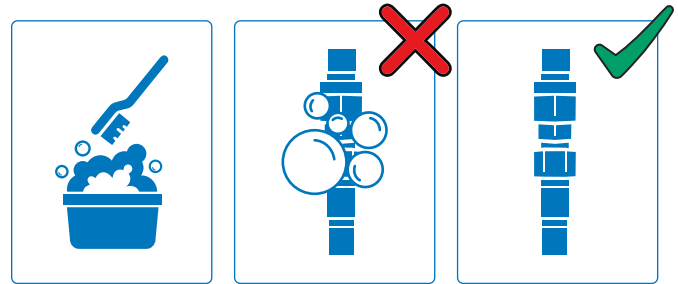

- Never use an open flame to check for gas leaks. Sparks or flames will cause a fire, explosion, damage to property, serious physical injury, or death.
- Only use the pressure regulator and hose assembly supplied with the grill, or one in conformity with local codes.

# Operation

## Lighting your grill

### Is it the very first time? Perform a Burn-off

Remove warming rack and run the main burners on high for 30 minutes. It is normal for the grill to emit an odor the first time it is lit. This odor is caused by the “burn-off” of internal paints and lubricants used in the manufacturing process and will not occur again.

### Main Burner Lighting

1. Open grill lid.
2. Push and slowly turn any main burner knob counter clockwise to HIGH position until pilot lights. Continue to push down on the control knob until the burner lights and then release (**Figure 1A**).
3. If the pilot does not light – immediately turn the control knob clockwise to the OFF position. Repeat step 2.
4. If the pilot and burner will not light in 5 seconds – turn the control knob clockwise to the OFF position. Wait 5 minutes for gas to dissipate. Repeat steps 2 and 3, or light with a match.

**NOTE:** Do not use the rear burner while operating the main burner.

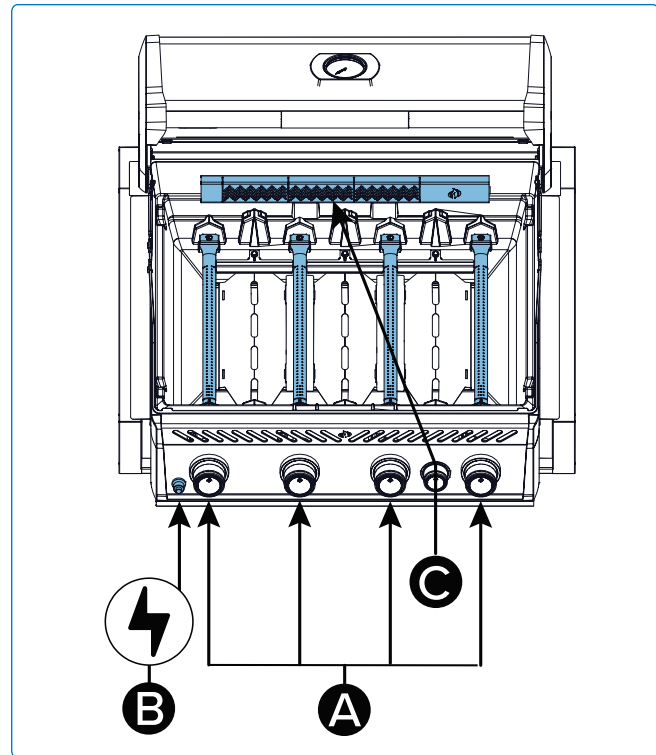
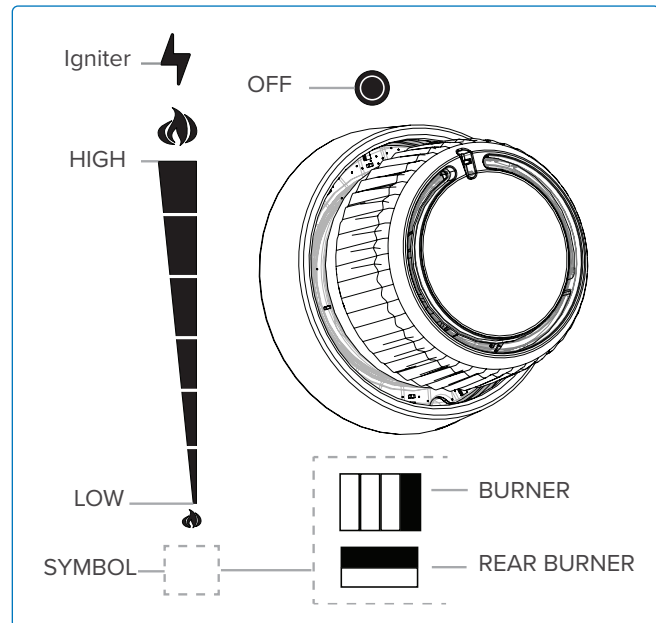

Fig. 1



### Rear Burner Lighting (if equipped)

1. Open grill lid.
2. Remove warming rack.
3. Push and slowly turn rear burner knob counter clockwise to HIGH position (**Fig 1 C**).
4. Press and hold igniter button until the burner lights, or light by match (**Fig 1 B**).
5. If the burner will not light – turn burner control knob clockwise to the OFF position. Wait 5 minutes. Repeat step 3 and 4.

### Alternative Ignition Instructions

1. Open the grill lid.
2. Light a long-reach match or butane lighter and position it close to the burner ports (**Fig. 2**).
3. Turn the corresponding burner knob counter clockwise to the HIGH position until it lights.

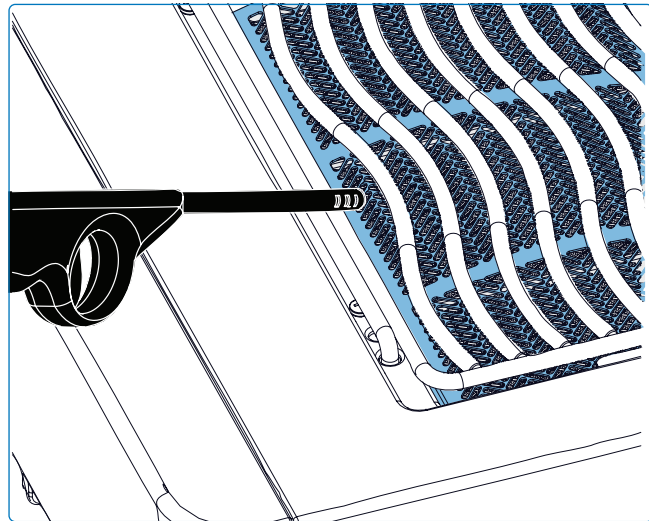
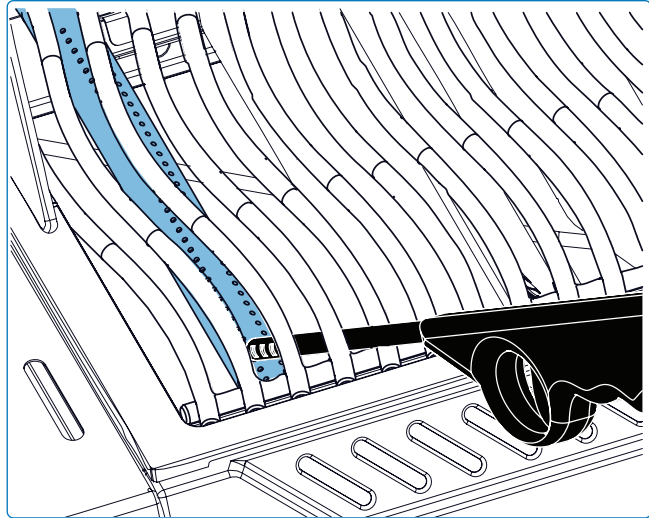
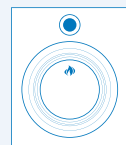

Fig. 2

### WARNING!

- Ensure all burner controls are in the OFF position before slowly turning on gas supply valve.
- Follow the lighting instructions carefully.
- Make sure the lid of the grill is OPEN while igniting.
- Do not adjust the grill while it is hot or in operation.
- Regularly clean grease out of the entire unit, including the grease tray to avoid build-up and grease fires.



## Grilling Instructions

### Main Burner Use

- Preheat the grill for searing by operating all main burners on HIGH with the lid closed for about 10 minutes.
- Grill foods that cook quickly, such as fish and vegetables, with the lid open.
- Cooking with the lid closed provides higher, more consistent temperatures. This helps cook meat evenly and can reduce cooking time.
- Lightly oil the cooking grids before preheating to reduce sticking when grilling lean meats such as chicken breast or pork.
- Cook foods that take longer than 30 minutes, such as roasts, indirectly. Light the burner opposite the food. See Indirect Grilling.
- Trim excess fat from meat to prevent flare-ups, or lower the grill temperature.
- In case of flare-ups, move food away from the flames and reduce the heat. Keep the lid open.

### Direct Grilling

This method is often used for searing, or food cooked for only a short time such as hamburgers, steaks, chicken, or vegetables. Place food on the cooking grids directly over the heat. Sear meat first to trap-in the juices and flavor. Lower the grill temperature to finish cooking to your preference.

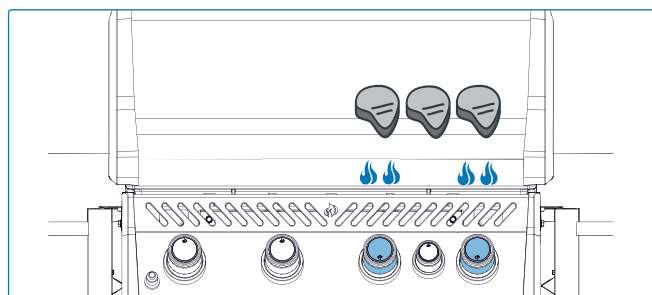

### Indirect Grilling

This method uses lower temperatures and circulates heat around the food cooking it slowly and evenly. Use this method to cook larger cuts of meat, or food prone to flare-ups such as roast, chicken, or turkey.

Turn one or more burners on and place food on the cooking grid where there is no flame, or burner on. Grilling at a lower temperature and slower cooking time results in more tender meats.

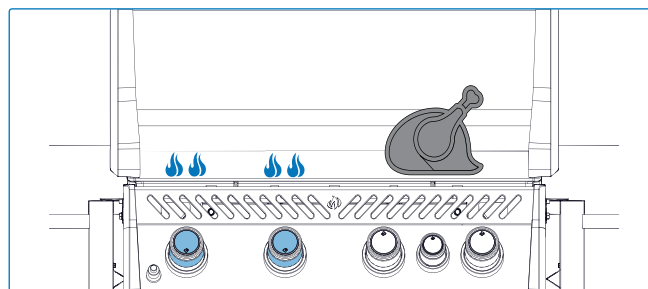

### Infrared Main Burner Use (if equipped)

Follow the “Main Burner Lighting” Instructions and operate on high for 5 minutes with the lid closed or until the ceramic burners glow red.

Cook the food directly on the grid(s) following the directions on the “Infrared Grilling Guide”. Food can be seared on the infrared burner and then transferred to the main burners of the grill to finish cooking over direct or indirect heat, depending on your taste and preference.

### DANGER!

- Never grill food directly on the flame side burner. It is designed for use with pots and pans only.
- Do not close side burner lid while it is operating or hot.
- DO NOT use a gas cylinder filled beyond 80%.
- Regularly clean grease out of the entire unit, including the grease tray, to avoid build-up and grease fires.



### BE CAREFUL!

The grill and the entire firebox can become very hot when in use.

## How to use the Rear Burner & Rotisserie

### Assembling Your Rotisserie Kit (if equipped)



#### NOTE:

Remove the warming rack prior to using the rear burner and spit rod. Extreme heat will damage the warming rack.

1. Install the rotisserie motor on the side of the grill using the mounting bracket(s). Some models have pre-mounted bracket (**Fig. 3**).
2. Once the bracket has been fastened to the grill, slide the rotisserie motor onto the bracket (**Fig. 3**).
3. Connect the spit rod extension. Slide the first rotisserie fork just past the middle of the spit rod and tighten into place. Thread the meat onto the spit rod and push the meat into the fork. Slide the second rotisserie fork on the opposite end of the spit rod and push the fork into the meat until secure. Tighten the fork into place (**Fig. 4**).
4. Carefully insert the pointed end of the spit rod into the rotisserie motor and set the opposite end across the hangers. The heavy side of the meat will naturally hang down to balance the load (**Fig. 5**).
5. Slide the stop bushing onto the spit rod until it is past the inside of the hood. This will secure the side to side movement of the spit rod (**Fig. 5**).
6. Tighten the stop bushing and spit rod handle. Place a metal dish under the meat to collect the drippings (**Fig. 5**).



#### IMPORTANT!

- Always wear gloves when handling components of the grill.

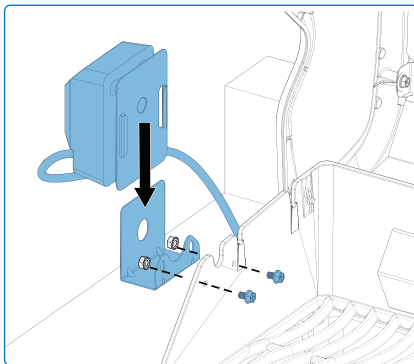

Fig. 3

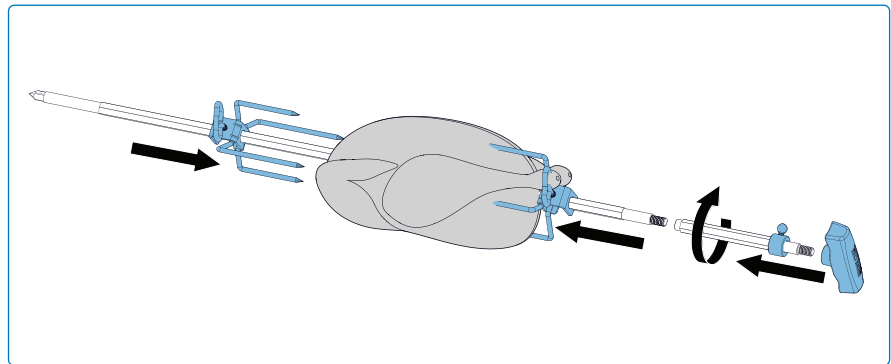

Fig. 4

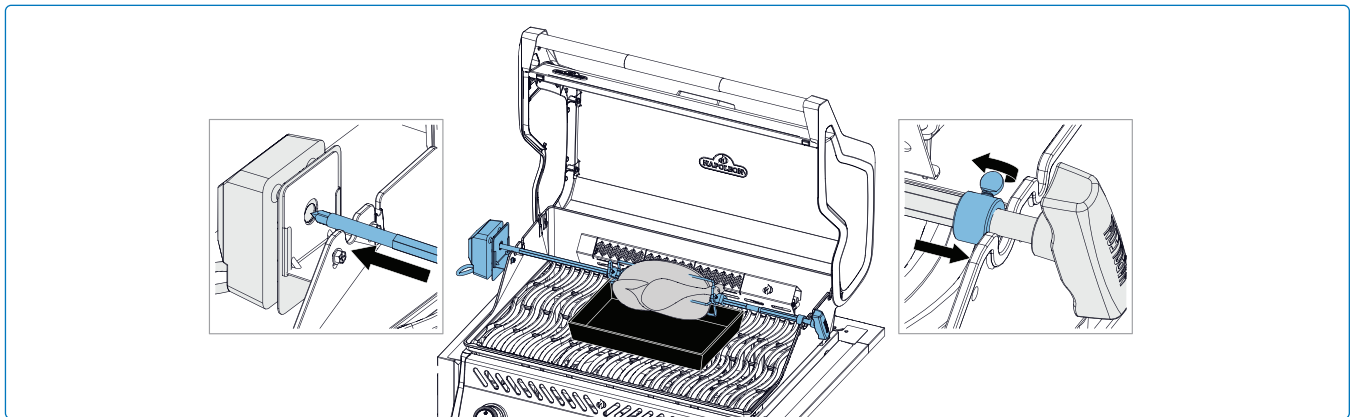

Fig. 5

### Tips about using the Rotisserie:

- Operate the rear burner on high until the meat browns. Reduce heat. Keep lid closed.
- Use a thermometer to check the internal temperature of the meat.
- Roasts and poultry should brown on the outside and stay tender on the inside.
- Use drippings to baste and make gravy.
- A 3-pound chicken takes approximately 1 ½ hours on medium to high.
- Be mindful of your rotisserie motor capacity. Never overload your equipment.
- Be sure to always set an evenly balanced load on your rotisserie.

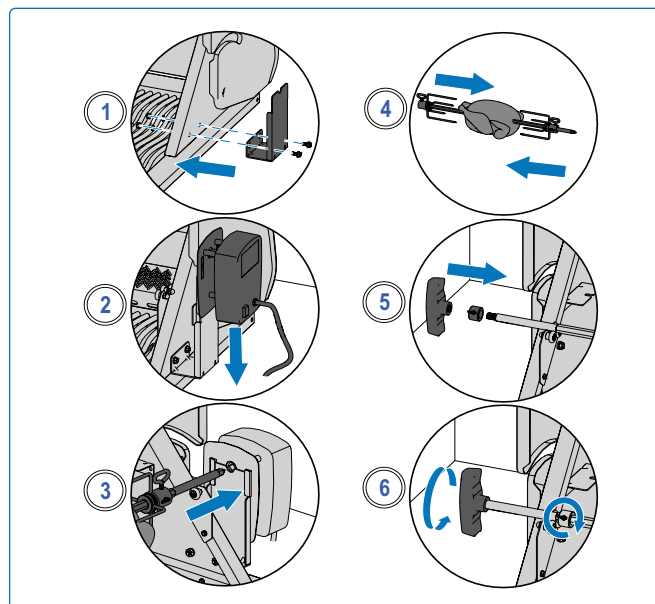

Fig. 6

### How to cook multiple chickens

1. Tie or skewer wings to the body of the chickens
2. Slide rotisserie fork onto spit rod.
3. Thread first chicken onto spit rod until it is held into place by the rotisserie fork. Tighten.
4. Thread next 2 chickens onto spit rod so all the chickens are close together.
5. Slide second rotisserie fork onto spit rod and push into chicken until all 3 chickens are squeezed together tightly. Tighten (**Fig. 6**).



### WARNING!

- Disassemble rotisserie components when finished cooking, wash with warm soapy water, and store indoors.
- Use heat resistant grilling gloves when handling the hot rotisserie components.
- Disconnect rotisserie plug from the outlet when the grill is not in use.



### DID YOU KNOW?

You can remove the cooking grids if they interfere with cooking larger cuts of meat.

## The Cooking Experience Checklist

Refer to this list every time you cook

- Read Owner's Manual**  
Read the Owner's Manual and all safety instructions before use.
- Clean Grease Tray**  
Always clean the grease tray before griddling to prevent fires and flare-ups.
- Check the Hose**  
Ensure the grill is off and cool. Inspect the hose for cuts or abrasions. Replace if damaged.
- Preheat the Appliance**  
Coat the grids with vegetable shortening and preheat to burn off residue and prevent sticking.
- Clean Grids**  
Use a brass brush for cast iron grids and a stainless steel brush for stainless grids. See **"Cleaning Instructions"** section..
- Prep Area**  
Keep utensils, seasonings, sauces, and dishes within reach. Never leave food unattended..
- Flip Once – Don't Peek**  
Avoid opening the lid too often. Flip food only once to maintain temperature and cooking times.
- Leave Space**  
Leave room between food items to move them easily during cooking.
- Use a Thermometer**  
Check food with a thermometer to ensure it is cooked thoroughly. Follow temperature guidelines for all meats, especially poultry.



### NOTE:

Stainless steel cooking grids are corrosion resistant and require less maintenance than cast iron grids.

## Seasoning Cast Iron Cooking Grids

This procedure must be done before first use and repeated every 3–4 uses to keep grids looking new.

1. Remove cast iron grids from the grill.
2. Wash the grids with warm, soapy water using a soft cloth. Pat dry and allow them to dry completely.
3. Apply a thin, even layer of fat or oil on both sides using a silicone brush.
4. Preheat the grill to 350°F–400°F (176°C–204°C).
5. Install the cooking grids and cook for 30 min.
6. Apply a second even coat of fat or oil to the grids and cook for another 30 min.
7. Grids are now seasoned and ready for use.



### NOTE:

If rust forms on the cast iron grids, remove it with a scouring pad or brass brush and repeat the seasoning process.



### COOKING PRO TIP!





Discover inspiring recipes and griddling techniques in Napoleon's cookbooks or visit [www.napoleon.com](http://www.napoleon.com)



### COOKING PRO TIP!

Applying a thin layer of cooking oil to the grill plate will help prevent delicate foods such as eggs or fish from sticking to the cooking surface.

# Cooking Guide

| Food  | Control Knob Setting   | Cooking Time          | Suggestions   |
|---|--|-----------------------|---|
| <br><b>Steak</b><br>1 inch (2.54 cm) thick.    | <b>HIGH</b><br>2 minutes each side.  | Rare – 4 minutes      | Ask for marbled fat in cut. Fat is a natural tenderizer and keeps meat juicy.   |
|   | <b>HIGH to MEDIUM</b><br>High heat 2 minutes each side then turn to medium heat. | Medium – 6 minutes    |   |
|   |  | Well Done – 8 minutes |   |
| <br><b>Hamburger</b><br>½ inch (1.27 cm) thick | <b>HIGH</b><br>2 minutes each side.  | Rare – 4 minutes      | Keep patties all the same thickness for equal cooking times. Patties 1 inch thick or more should be cooked using indirect heat. |
|   | <b>HIGH</b><br>2 ½ minutes each side.  | Medium – 5 minutes    |   |
|   | <b>HIGH</b><br>3 minutes each side.  | Well Done – 6 minutes |   |
| <br><b>Pork Chops</b>                          | <b>MEDIUM</b>  | 6 minutes each side   | Choose thick cuts for more tender meat. Trim off excess fat.  |
| <br><b>Lamb Chops</b>                        | <b>HIGH to MEDIUM</b><br>High for 5 minutes then Medium until finished.          | 15 minutes each side  | Choose thick cuts for more tender meat. Trim off excess fat.  |
| <br><b>Hot dogs</b>                          | <b>MEDIUM to LOW</b>   | 4 – 6 minutes         | Select larger wieners and slit lengthwise before cooking.   |

**These are general guidelines.**  
 Please refer to the health authority recommendations for more detailed information.



### COOKING PRO TIP!

Choose the right kinds of food to cook. Your grill excels at cooking foods hot and fast.

Although you can cook large chunks of meat on a grill over a low heat, a Napoleon gas or charcoal grill will produce better results.



### OIL AND FAT SUGGESTION!

- Grapeseed Oil,
- Sunflower Oil,
- Flaxseed Oil,
- Avocado Oil
- Canola Oil.

If not available, select an oil or fat that has a high smoke point.

Do not use salted fats like butter or margarine.

# Cleaning Instructions

## First Time Use

1. Wash the cooking grids by hand with water and mild dish soap to remove any residue from manufacturing. DO NOT wash grids in a dishwasher.
2. Rinse thoroughly with hot water and dry completely with a soft cloth to prevent moisture from entering the cast iron (**Fig. 7**).

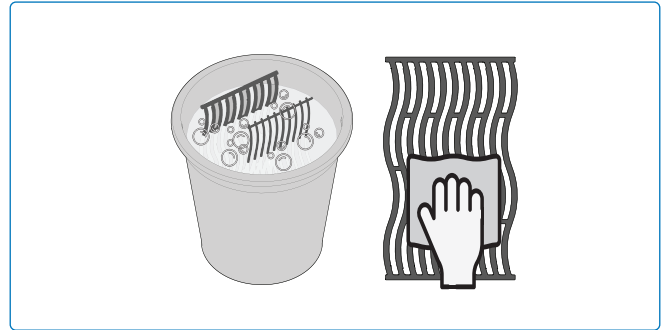

Fig. 7

## Cast Iron Grids

- Season the grids to create a protective coating that helps prevent corrosion. See Grilling Tips – How to Season Your Cast Iron Cooking Grids.

## Stainless Steel Grids

- Clean stainless steel cooking grids by preheating the grill and using a wire brush to remove residue (**Fig. 8**).
- Stainless steel grids will permanently discolor from regular use because of high grilling temperatures.

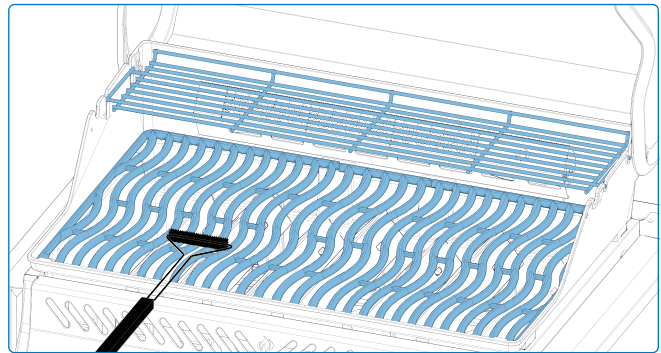

Fig. 8

## Infrared Side Burner

- Most drippings and food particles that fall on the infrared burner surface incinerate immediately because of the high heat.
- DO NOT clean the ceramic tile with a wire brush.
- DO NOT use water or other liquids to clean the burner. Sudden temperature changes will cause the ceramic tile to crack.
- Light the burner and operate on high for 5–10 minutes to remove any leftover residue (**Fig. 9**).

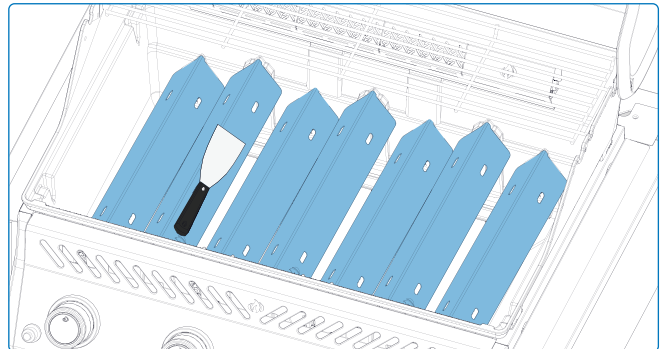

Fig. 9



### DANGER!

- Always wear protective gloves and safety glasses when cleaning your grill.
- Accumulated grease is a fire hazard.

## Inside of the Grill

1. Remove the cooking grids.
2. Use a brass wire brush to clean loose debris from the sides and the underside of the lid.
3. Scrape the sear plates with a putty knife or scraper, then use a wire brush to remove ash.
4. Remove the sear plates and brush debris from the burners with a wire brush (**Fig. 10**)
5. Sweep all debris from inside the grill into the drip pan.

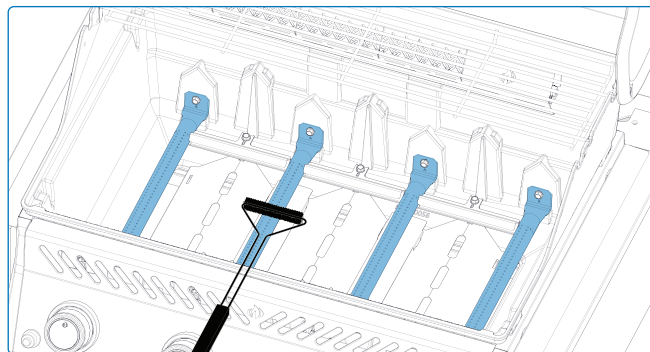

Fig. 10

## Drip Tray

Every grill head, side burner, and drop-in burner has a corresponding drip pan. The drip pan is easily accessible through doors or openings.

- Grease and excess drippings collect in the drip pan beneath the grill and flow into the disposable grease tray (if applicable).
- Only use Napoleon-approved liners in the drip pan. **DO NOT** use aluminum foil, sand, or any other unapproved material, as this prevents grease from draining properly.
- Clean the drip pan regularly—about every 4–5 uses—to prevent grease build-up (**Fig. 11**).

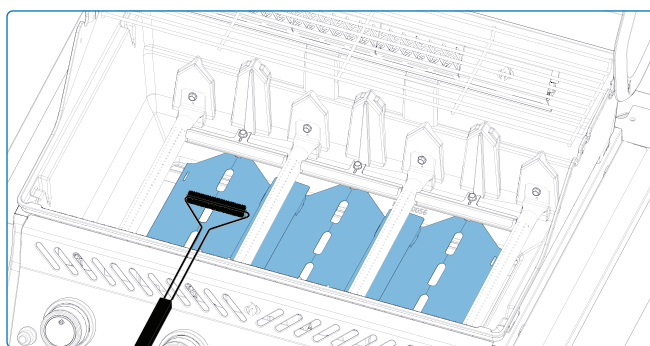

Fig. 11

## Cleaning Steps

1. Slide the drip pan from the grill to access the disposable grease tray or to clean the drip pan (**Fig. 12**).
2. Scrape the drip pan with a putty knife or scraper.
3. Replace the disposable grease tray every 2–4 weeks, depending on grill usage (if applicable).
4. Contact your Napoleon dealer for replacement supplies.

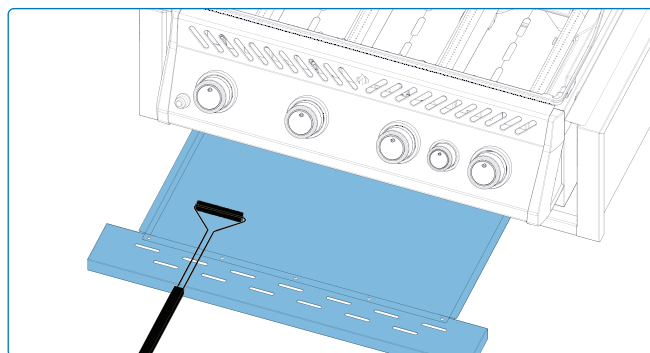

Fig. 12

## ! WARNING!

- Ensure all burners are turned off and the grill is completely cool before cleaning.
- Do not use oven cleaner on any part of the grill.
- Do not place cooking grids or any grill parts in a self-cleaning oven.
- Clean the grill in an area where cleaning solutions will not damage decks, lawns, or patios.
- Barbecue sauce and salt are corrosive and will cause rapid deterioration of grill components unless cleaned regularly.

## Control Panel

Clean with warm, soapy water only. The text is printed directly on the control panel and will gradually rub off if abrasive or stainless steel cleaners are used. Proper cleaning will keep the text dark and legible **(Fig. 13)**.

## Aluminum Castings

Clean with warm, soapy water. Aluminum does not rust, but high temperatures and weathering can cause surface oxidization that appears as white spots. See **“Maintenance Instructions”** for tips on preventing aluminum oxidization.

## Outside Appliance Surface

- Only use a non-abrasive cleaner. Abrasive cleaners or steel wool will scratch the finish.
- Always wipe in the direction of the grain.
- Handle porcelain enamel components with care. The baked-on enamel finish is glass-like and will chip if struck.
- Stainless steel parts discolour overtime when heated and will turn a golden or brown hue. This is normal and won't affect the performance of the appliance.

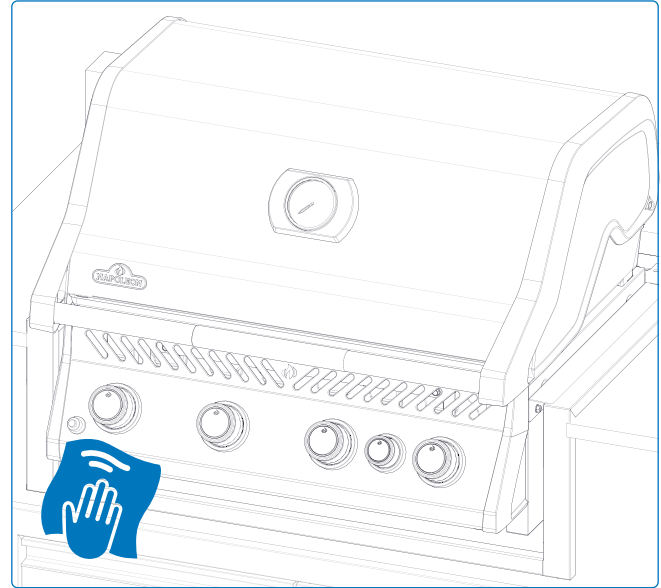

Fig. 13

### DANGER!

- Do not use abrasive cleaners or steel wool on any painted, porcelain, or stainless steel parts of your grill because it will scratch the finish.
- Avoid unprotected contact with hot surfaces.



### SAFETY FIRST!

Always wear protective gloves and safety glasses when servicing your appliance.

## Insect Screen and Burner Ports

Spiders and insects are often attracted to small, enclosed spaces. To reduce this risk, Napoleon equips burners with an insect screen on the air shutter. This helps prevent nests inside the burner but does not eliminate the problem entirely.

A nest or web can cause the burner flame to turn yellow or orange and may lead to fire or flashback at the air shutter beneath the control panel.

1. Remove the screw(s) attaching the burner to the back wall of the grill. Slide the burner back and upward to remove (**Fig. 14**).
2. Clean the inside of the burner using a flexible venturi tube brush. Shake loose debris from the burner through the gas inlet (**Fig. 15**).
3. Inspect the burner ports and valve orifices for blockages. Cooking debris and corrosion can close ports over time.
4. Clean blocked burner ports with an open paper clip or the supplied port maintenance bit.
5. If needed, drill out blocked ports using the supplied drill bit in a cordless drill. This can be done with the burner attached, but removal makes it easier.
6. Do not flex the drill bit during use, or it may break.
7. Use the drill bit only for burner ports. Do not use it on the brass orifices that regulate gas flow.
8. Do not enlarge the burner port holes.
9. Ensure the insect screen is clean, tight, and free of lint or debris.
10. Reinstall the burner by reversing the removal steps.
11. Ensure the valve enters the burner correctly during installation.
12. Reinstall the sear plate mount and tighten screws to complete reassembly.

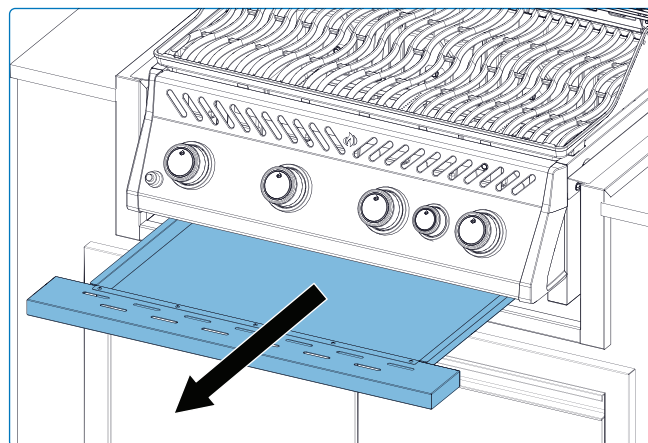

Fig. 14

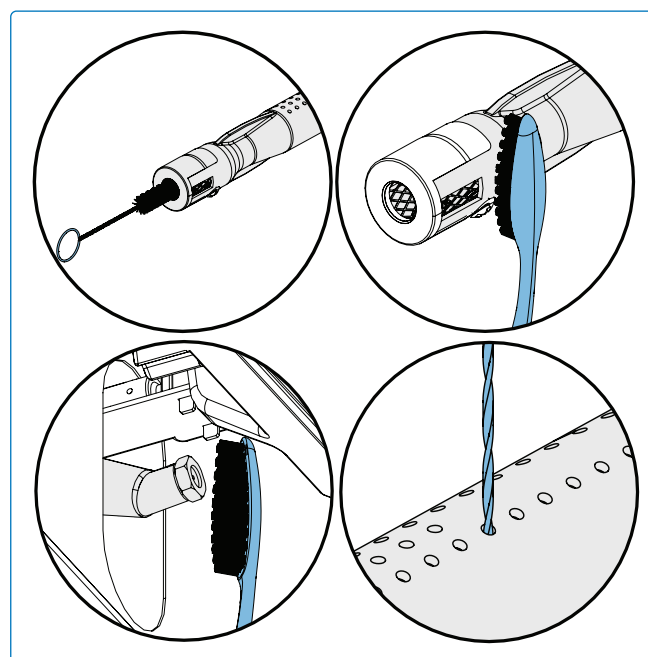

Fig. 15

### DANGER!

- It is very important the valve/orifice enters the burner tube when reinstalling the burner after cleaning and before lighting your grill, or a fire or explosion could occur.
- Turn off gas at the source and disconnect the unit before servicing.

## Maintenance Instructions

### Recommendations

This grill should be inspected and serviced annually by a qualified technician.

- DO NOT obstruct the flow of ventilation or combustion air.
- Keep all ventilation openings in the cylinder enclosure clear of debris. These openings are located on the sides of the cart or enclosure, and on the front and back of the bottom shelf

### Flame Appearance

- Flames should appear dark blue with light blue tips and occasional yellow (Fig. 16)
- Insufficient airflow will cause soot buildup and lazy yellow flames.
- Excessive airflow will cause flames to lift erratically and make ignition difficult. See Troubleshooting.
- The air shutter is factory set and should not require adjustment under normal conditions. Adjustments may be needed only in extreme situations.

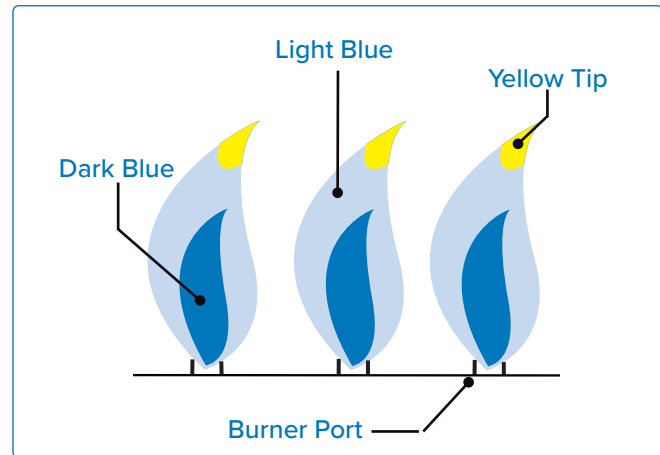

Fig. 16



#### NOTE:

Infrared burners have no air adjustment.



#### IMPORTANT!

- Orifice changes and air shutter adjustments must only be performed by a qualified gas installer.



#### WARNING!

- Keep the grill away from combustible materials, gasoline, and other flammable vapors and liquids.
- Do not leave food particles or grease on the grill. They can attract rodents, which are unsanitary and may chew wires, causing permanent damage to electrical components.



#### WE WANT TO HELP!

Contact the Napoleon customer solutions department for recommended replacement parts +31 (0) 88 588 66 55.

## Technical Data

The following table lists Gross Heat Input and Gas Usage values per unit, along with all certified gases and pressures. Verify that the information on the rating plate corresponds with this list.



**NOTE:** Only use regulators that supply the pressure listed here.

| Gas Category | Main Burner Orifice | Rear Burner Orifice | Gross Heat Input (Total)                        | Gas Usage (Total)                                 | Gases / Pressures                           | Countries   |
|--------------|---------------------|---------------------|---|---|---|---|
| 3B/P(30)     | 0.91 mm             | 1.0 mm              | Main Burner<br>13.6 kW<br>Rear Burner<br>3.7 kW | Main Burner<br>989 g/hr<br>Rear Burner<br>269 g/h | Butane<br>30mbar<br>Propane<br>30mbar       | AL, BE, BG,<br>CY, CZ, DK,<br>EE, FI, FR,<br>GB, GR, HR,<br>HU, IS, IT, LT,<br>LU, MT, NL,<br>NO, PL, RO,<br>SE, SI, SK, TR |
| 3+(28-30/37) | 0.91 mm             | 1.0 mm              |   |   | Butane<br>28–30 mbar,<br>Propane<br>37 mbar | BE, CH, CY,<br>CZ, ES, FR,<br>GB, GR, IE,<br>IT, LT, LU, LV,<br>PL, PT, SI,<br>SK, TR                                       |
| 3P(37)       | 0.91 mm             | 1.0 mm              |   |   | Propane<br>37 mbar                          | BE, CH, CZ,<br>ES, FR, GB,<br>GR, HR, HU,<br>IE, IT, LT, NL,<br>PL PT, RO,<br>SI, SK, TR                                    |
| 3B/P(50)     | 0.79 mm             | 0.88 mm             |   |   | Butane<br>50 mbar,<br>Propane<br>50 mbar    | AT, CH, CZ,<br>DE, SK   |



### REGISTER YOUR APPLIANCE!

Go to [napoleon.com](http://napoleon.com) or your Assembly Guide for replacement part instructions.



### WE WANT TO HELP!

Napoleon is here to ensure your griddling experience is memorable. Contact us if you require additional help.

## Stainless in Harsh Environments

Stainless steel oxidizes or stains in the presence of chlorides and sulfides, especially in coastal regions, warm and highly humid areas, and around pools and hot tubs. These stains look like rust, but they can be easily removed or prevented. Wash stainless and chrome surfaces every 3-4 weeks. Clean with warm soapy water.

### Burner Maintenance

- Extreme heat and a corrosive environment can cause surface corrosion to occur even though the burner is made from heavy wall 304 stainless steel.

### Maintenance and Protection of Infrared Burners

Infrared burners are built for long-lasting performance. To keep them working properly, protect the ceramic surfaces from cracks. A cracked surface will cause the burner to malfunction.



### IMPORTANT!

- Damage caused by not following these instructions is not covered under warranty.

### Clearance Ventilation of Hot Air

- Hot air must have a way to escape the appliance for the burners to function properly.
- The burners can become deprived of oxygen if the hot air is not allowed to escape causing them to backflash.

## Steps to Avoid Damaging Ceramic Surfaces

1. Never use water to douse flames or control flare-ups (**Fig. 17**)
2. Keep cold water (rain, sprinklers, hoses, etc.) away from hot ceramic burners. Sudden temperature changes will crack the ceramic tile.
3. Do not operate the burner if the ceramic is wet. Steam buildup can create pressure that cracks the ceramic.
4. Avoid repeated soaking. Excess water causes the ceramic to swell, crack, and crumble.
5. If you find standing water in the grill, check the ceramic for moisture. Remove the burner, turn it upside down to drain, and allow it to dry thoroughly indoors.
6. Protect the burner from impact. Be careful when handling cooking grids and accessories near the ceramic.

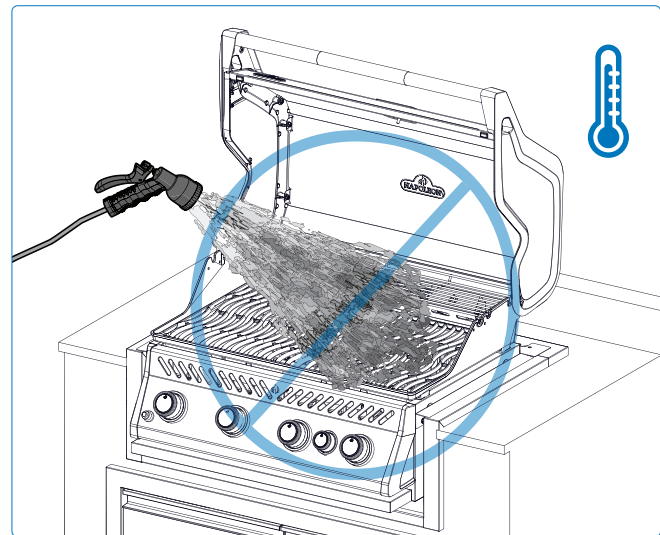

Fig. 17



### DANGER!

- Turn off gas at the source and disconnect the unit before servicing.
- Maintenance should only be done when the grill is cool to avoid the possibility of burns.
- A leak test must be performed annually and when any component of the gas train is replaced, or when the smell of gas is present.



### SAFETY FIRST!

Never cover more than 75% of any main or side burner cooking surface with any solid metal (e.g. grills or pans)

# Troubleshooting

## Lighting Problems

- Main, rear or side burners will not light with the igniter, but will light with a match.
- Burners will not cross light each other.

|                       | Possible causes                               | Solution  |
|-----------------------|---|---|
| Main Burner           | JETFIRE™ outlet is dirty or clogged           | Clean JETFIRE™ outlet with a soft bristle brush.  |
|                       | Dirty or corroded cross light brackets        | Clean or replace as required.   |
| Rear and Side Burners | Lifting flames on burner                      | Close the air shutter as described in the “ <b>Maintenance Instructions – Combustion Air Adjustment</b> ” section of this Owner’s Manual.<br><b>IMPORTANT!</b> This adjustment must be performed by a qualified gas installer.    |
|                       | Loose electrode wire or switch terminal wires | Verify that all lead wires from the module to the ignition switch (if equipped) are securely attached to their respective terminals.<br>Ensure the electrode wire is firmly connected to the terminal on the back of the igniter. |

## Peeling Paint

- Paint appears to be peeling.

| Possible causes                     | Solution   |
|-------------------------------------|--|
| Grease build-up on inside surfaces. | This is not a defect. The lid and hood finish is porcelain or stainless steel and will not peel. What appears to peel is hardened grease that dries into paint-like flakes. Regular cleaning will prevent this. See the “Cleaning Instructions” section for details. |

### Noises and Uneven Heat

- Humming regulator.
- Excessive flare-ups and uneven heat.

| Possible causes                                | Solution   |
|--|--|
| Normal humming noise on hot days.              | This isn't a defect. It's caused by internal vibrations in the regulator and doesn't affect the performance or safety of the grill. Humming regulators WILL NOT be replaced. |
| The cylinder valve was opened too quickly.     | Open cylinder valve slowly.  |
| Sear plates installed incorrectly.             | Ensure sear plates are installed with holes towards the front, and the slots on the bottom. See Assembly Guide Instructions.   |
| Improper heating.                              | Preheat the appliance with the burners on high for 10 to 15 minutes.   |
| Excessive grease and ash build-up on drip pan. | Clean drip pan regularly. Do not line pan with aluminum foil. Refer to the " <b>Cleaning Instructions</b> " section.   |

### Infra-red Burner Flashes Back

- During operation the burner abruptly makes a loud whoosh sound, followed by a continuous blow-torch type sound and grows dim or has a large flame on start up.

| Possible causes   | Solution  |
|---|---|
| Ceramic tiles overloaded with grease drippings and build-up. Ports are clogged.                   | Turner burner OFF and allow to cool for at least 2 minutes. Reignite burner and burn on HIGH for at least 5 minutes, or until the ceramic tiles are evenly glowing red. |
| Burner overheated because inadequate ventilation. Too much grill surface covered by grill or pan. | Ensure no more than 75% of the grill surface is covered by objects or accessories. Turn burner OFF and allow to cool for at least 2 minutes. Reignite.                  |
| Leaking gasket surrounding the ceramic tile, or a weld failure in the burner housing.             | Allow burner to cool and inspect very closely for cracks. Contact your authorized Napoleon dealer to order replacement burner assembly if any cracks are found.         |
| Improper heating.   | Preheat grill with both main burners on high for 10 to 15 minutes.  |
| Excessive grease and ash build on sear plates and in drip pan.                                    | Clean sear plates and drip pan regularly. Do not line pan with aluminum foil. Refer to " <b>Cleaning Instructions</b> ".  |

### Gas Flow

- Low heat or low flame when valve is turned to high.
- Burners burn with yellow flame, accompanied by the smell of gas.
- Flames lift away from burner, accompanied by the smell of gas, and possible lighting difficulties.
- Burner output on HIGH, but setting is LOW. Rumbling noise and fluttering blue flame at burner surface.

| Possible causes                        | Solution  |
|--|---|
| Propane – improper lighting procedure. | Ensure lighting procedure is followed carefully. All gas valves must be in the OFF position when the tank valve is turned on. Turn tank on slowly to allow pressure to equalize.<br>See <b>Operation – "Lighting Instructions"</b> section.   |
| Improper preheating.                   | Preheat grill with both main burners on high for 10 to 15 minutes.  |
| Possible spider web or other debris.   | Thoroughly clean nest or webs out of your burner orifice by removing it and following instructions in this manual. See <b>"Cleaning Instructions"</b> section.  |
| Improper air shutter adjustment.       | Open or close air shutter slightly according to this manual. See <b>"Maintenance Instructions"</b> section.<br><b>IMPORTANT!</b> This must be done by a qualified gas installer.  |
| Lack of gas.                           | Check gas level in propane cylinder.  |
| Supply hose is pinched.                | Reposition supply hose as necessary.  |
| Propane regulator in low flow state.   | Turn the burners off and close the tank valve, wait 5 minutes before fully re-opening the valve, allow a few seconds for the pressure to equalize before following the Lighting Instructions to start the grill. Ensure igniting procedure is followed carefully every time you cook. All gas valves must be OFF when the tank valve is turned on. Always open the tank valve slowly. |

# NAPOLEON PRODUCT WARRANTY



## FOR LE, LEX (BARBECUE CART AND HEADS), ROGUE® AND PRO 605 CSS

### 15 Years Napoleon Gas Grills Limited Warranty

NAPOLEON warrants that the components of your new NAPOLEON product will be free from defects in materials and workmanship from the date of purchase for a period of:

|  |                             |
|--|-----------------------------|
| Aluminum Castings / Stainless Steel Base .....   | 15 Years                    |
| Stainless Steel Lid .....                        | 15 Years                    |
| Porcelain-Enameled Lid.....                      | 15 Years                    |
| Stainless Steel Cooking Grids.....               | 15 Years                    |
| Stainless Steel Tube Burner .....                | 10 Years <sup>plus 15</sup> |
| Stainless Steel Flame Protection Inserts.....    | 5 Years <sup>plus 15</sup>  |
| Porcelain-Enameled Cast Iron Cooking Grids ..... | 5 Years <sup>plus 15</sup>  |
| Ceramic Infrared Burner (Excluding Mesh).....    | 5 Years <sup>plus 15</sup>  |
| All Other Parts .....                            | 2 Years                     |

**Plus 1d:** refers to an extended warranty period, during which we supply spare parts to the purchaser at 50% of the current retail price for the lifetime\* of the grill.

**Plus 15:** refers to an extended warranty period, during which we supply spare parts to the purchaser at 50% of the current retail price for an additional 15 years.

**Plus 10:** refers to an extended warranty period, during which we supply spare part to the purchaser at 50% of the current retail price for an additional 10 years.

**\*Lifetime** refers to a warranty period of 30 years.

**This warranty is valid in:** the European Union, Switzerland, Andorra, San Marino, Norway, Iceland and Liechtenstein.

**The customer's legal entitlements in the event of defects in accordance with WKRL - (EU) 2019/711) are not affected, restricted or altered by the present warranty. The exercise of statutory entitlements is to take place free of charge.**

## WARRANTY CONDITIONS AND LIMITATIONS

NAPOLEON guarantees that its products are free from defects exclusively to the original purchaser, and only insofar as the purchase took place through an official NAPOLEON dealer. The following conditions and restrictions apply:

The present manufacturer's warranty is not transferable nor viable for extension under any circumstances or by any of our representatives. The gas grill must be installed by a licensed, authorized service technician or contractor.

Installation must take place in accordance with the installation instructions provided, as

well as all local and national building and fire codes. This limited warranty does not cover damage caused by improper operation, lack of maintenance, grease fire, environmental exposure, accidents, modification, abuse, or neglect. The installation of spare parts from other manufacturers voids the present warranty. The discoloration of plastic elements due to the application of chemical cleaning agents or exposure to sunlight is not covered under this warranty.

This warranty also excludes any of the following: Scratches, dents, paint defects, coatings, corrosion or discoloration caused by exposure

to heat or abrasive and chemical cleaners, as well as chips to porcelain-coated parts and any components used in the installation of the gas grill. If a part deteriorates to the point where it becomes inoperable (due to rusting or burning through) within the warranty period, the customer will be issued with a replacement part.

After the first year, NAPOLEON has the authority under this warranty to waive any warranty obligation at its free discretion by refunding the original purchaser to the tune of the wholesale price of the relevant defective warranty parts.

NAPOLEON accepts no responsibility for any installation, labor hours or other costs or expenses associated with the reinstallation of a warranty part. Costs of this nature are not covered by the present warranty.

Notwithstanding any regulations under this warranty, NAPOLEON's liability under this warranty is defined by the foregoing, and does not cover any incidental, consequential, or indirect damage in any case whatsoever.

This warranty defines NAPOLEON's duties and liability with respect to the NAPOLEON gas grill. NAPOLEON assumes no further liability in connection with the sale of this product, nor does it authorize any third party to assume any other liability on its behalf.

NAPOLEON assumes no responsibility for: Overheating, extinguishing of the flame by environmental factors such as strong winds or inadequate ventilation.

NAPOLEON does not accept liability for any damage to the gas grill caused by the weather, hail, rough handling, aggressive chemicals or cleaning agents. Warranty claims must be accompanied by the proof of purchase or a copy thereof stating the serial and model number.

NAPOLEON reserves the right to have the product or any part thereof inspected by one of its representatives prior to the fulfilment of any warranty obligation.

NAPOLEON does not bear shipping costs, labor hours or export duties.

#### **GUARANTOR:**

NAPOLEON EUROPE | WOLF STEEL EUROPE B.V.  
De Riemsdijk 22 | 4004LC | Tiel | Gelderland Netherlands

☎ +31 (0) 88 588 66 55

✉ [eu.info@napoleon.com](mailto:eu.info@napoleon.com)



# 50 Years of Home Comfort Solutions.



NAPOLEON® products are protected by one or more U.S. and Canadian and/or foreign patents or patents pending.



### Address

**Wolf Steel Ltd.**  
De Riemsdijk 22, 4004 LC,  
Tiel, The Netherlands  
10-12 Home Farm, Meriden Road,  
Berkswell, CV7 7SL,  
United Kingdom  
24 Napoleon Road, Barrie,  
Ontario, L4M 0G8, Canada



### Telephone

**Europe**  
+31 (0) 88 588 66 55

### Online

✉ [eu.info@napoleon.com](mailto:eu.info@napoleon.com)  
🌐 [www.napoleon.com](http://www.napoleon.com)